

NEW LINE



| B I O T R I T U R A T O R I |



www.caravaggi.com - info@caravaggi.com



La cippatrice modello CIPPO 25, è una macchina adatta per la cippatura di legno di potatura avente diametro massimo pari a 25 cm. Il sistema di alimentazione avviene tramite due rulli idraulici autoallineanti con motori indipendenti, che dosano il flusso del materiale in entrata. La presenza di un dispositivo elettronico No-Stress, garantisce la salvaguardia del motore in caso di sovrasforzo. La bocca di lancio del prodotto cippato è regolabile a 360° mediante apposita leva e permette di lanciare il prodotto ad una altezza pari a 2,50 mt. Il tamburo cippante è dotato di n°3 lame regolabili e di n°1 controlama fissa.

- Apertura massima rullo mobile: cm 25x25
- Tramoggia reclinabile per il trasporto su strada
- Carrello per il trasporto su strada con traino da 25 ed 80 Km/h.



Die Hackmaschine Modell CIPPO 25 ist eine Maschine, die sich Zerhacken von Traghholz mit einem maximalen Durchmesser von 25 cm eignet. Das Versorgungssystem erfolgt über selbst ausrichtende hydraulische Rollen mit unabhängigen Motoren, die den Materialfluß am Eingang dosieren. Eine elektronische No-Stress-Vorrichtung schützt den Motor vor Überbeanspruchung. Die Wurföffnung des zerhackten Produkts kann mit dem dafür vorgesehenen Hebel bis zu 360° reguliert werden und ermöglicht, das Produkt bis zu einer Höhe von 2,50 m zu werfen. Die Schnitzscheibe ist mit 3 regulierbaren Messern und einem festen Gegenmesser ausgestattet.

- Verfügbare Ausführungen: Diesel 60 PS/44 kW oder PTO (empfohlene Mindestleistung 60 PS/44 kW).
- Maximale Öffnung der beweglichen Rolle: 25x25 cm
- Für den Transport auf der Straße regulierbarer Trichter
- Für den Straßenverkehr von 25 bis 80 Km/h zugelassener Wagen mit Anhänger



Le déchiqueteur modèle CIPPO 25 avec son volant équipé de 3 lames réglables et d'une contre lame fixe est une machine spécialement adaptée au déchiquetage de banches, jusqu'à un diamètre maximum de 25 cm. Particulièrement destiné aux élagueurs.

- Alimentation avec 2 rouleaux hydrauliques autoalignés moteurs indépendants qui dosent l'entrée des branches.
- Equipé d'une régulation électronique "no stress" garantissant la fiabilité et la sauvegarde du moteur en cas de surcharge de produit.
- Conduit d'évacuation à 2,50 m environ du produit avec rotation à 360° à l'aide d'une poignée pour un meilleur confort d'utilisation.
- Ouverture maximum du rouleau mobile 25 cm x 25 cm.
- Trémie repliable pour le déplacement sur route.
- Châssis routier.



The CIPPO 25 is a machine designed for reducing the result of pruning to chip form maximum diameter 25 cm. It is fed by two self roller with independent motors that metres the flow of incoming material. The electronic "No-stress" device, guarantee the engine safeguard in case of overstress. The chip delivery nozzle can be adjuste through 360° by means of a lever and can launch material up to a heigh of 2.5 metres. The chipping drum is fised with three adjustable moving blades and a fixed counter-blade.

- Maximum mobile roller opening: 25x25 cm
- Overturning hopper for road transport
- Trailer for road transport with tow to 25 and 80 Km/h



La CIPPO 25 es una máquina concebida para reducir en virutas las escamondaduras y las podadas con un diámetro de hasta 25 cm. El sistema de alimentación es accionado por dos rodillos hidráulicos de alineación automática con motores independientes que dosifican el flujo de material que entra. La presencia de un dispositivo electrónico "no-stress" garantiza la protección del motor en caso de esfuerzo excesivo. La boca de evacuación del producto triturado es regulable a 360° mediante una palanca y permite lanzar el producto desde una altura de 2,50 metros. El tambor triturador está dotado de 3 cuchillas móviles y de una contracuchilla fija.

- Versiones disponibles: diesel 60 CV / 44 kW o PTO (potencia mínima recomendada 60 CV / 44 kW)
- Apertura máxima del rodillo móvil: cm 25 x 25
- Tolva abatible para el transporte por carretera
- Carro para el transporte por carretera con remolque de 25 y 80 km./h.



A máquina de lascas modelo Cippo 25, é uma máquina adequada para a execução de lascas de madeira de poda que tenha um diâmetro máximo equivalente a 25 cm. O sistema de alimentação ocorre por meio de dois rolos hidráulicos auto-alinhantes com motores independentes que dosam o fluxo de material na entrada. A presença de um dispositivo eletrônico No-Stress, garante a salvaguarda do motor em caso de sobrecarga. A boca de lançamento das lascas é regulável a 360° por meio da respectiva alavanca e permite lançar o produto a uma altura equivalente a 2,5 m. O tambor para a execução das lascas é dotado de 3 lâminas reguláveis e de 1 contra lâmina fixa.

- Abertura máxima rolo móvel: cm. 25x25.
- Moega reclinável para o transporte em estrada.
- Carro para o transporte em estrada com tração de 25 e 80 Km/h.

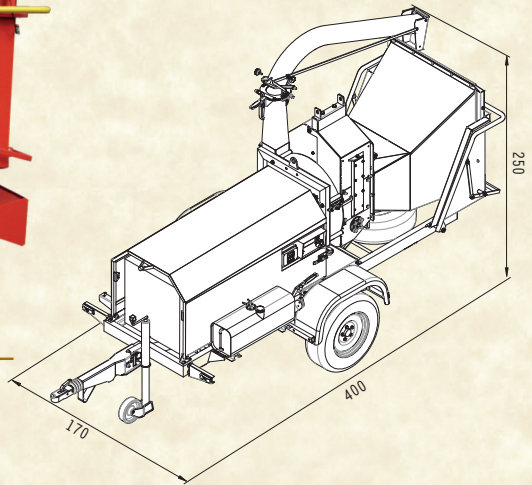

I prodotti sono soggetti ad evoluzione tecnica ed i prospetti potrebbero non essere aggiornati.
As it is company policy to aim continual improvement, the Manufacturer reserves the right to modify any part of the design or specifications without prior notice.

POWER IN HP/KW		LAME E CONTRO LAME	Ø CIPPABILE CM.	PRODUZIONE m ³ /h*	PESO MEDIO MACCHINA KG.	DIMENSIONI CM.			DIMENSIONI ALL'IMBALLO CM.
DIESEL	TRATTORE					LARGHEZZA	LUNGHEZZA	ALTEZZA	
60/44	60+120	3 + 1	25	14*	1600	170	400	250	170/400/220
DIESEL	PTO	BLADES AND COUNTER/BLADES	Ø TO BE CUT CM.	OUTPUT m ³ /h*	WEIGHT OF BASE MACHINE KG.	DIMENSIONS CM.			PACKING DIMENSIONS CM.

* Il dato citato è legato alle caratteristiche del prodotto da tritare e alla potenza utilizzata

* The mentioned datum depends from the product to be shredded and from the power

