

NEW SYSTEM



TRITURATORI



www.caravaggi.com - info@caravaggi.com



La TRITO è un trituratore polivalente per il riciclaggio e lo smaltimento di qualsiasi tipologia di rifiuto: ad esempio carta e cartoni anche spessorati, bottiglie e cassette in plastica, paraurti in vetroresina, scarti di falegnameria, rifiuti farmaceutici ed ospedalieri.

Grazie alla vasta gamma e alle diverse tipologie di lame è in grado di soddisfare le più svariate esigenze.

La produzione di materiale truciolato varia in relazione alla tipologia dei pezzi da triturare ed alla pezzatura che si vuole ottenere. E' dotato di un sistema di sicurezza di inversione e rotazione in caso di sovraccarico.

E' una macchina versatile, adatta ai diversi tipi di scarti, è a basso consumo di energia e bassa rumorosità; quindi particolarmente adatte alle piccole e medie imprese.



The TRITO is a multi-purpose shredder ideal for recycling garbage disposal of any type such as paper, cardboard even of thickness, plastic bottles and boxes, fiberglass bumpers, carpentry scraps, pharmaceutical and hospital wastes. Thanks to the wide range and to the different types of blades it is able to satisfy the several and various requirements.

The production of the chipped material varies according to the type of the pieces to be shredded and the size to be obtained.

It is equipped with a safety system consisting in a rotation and reverse application in case of overloading.

A versatile machine, ideal for different kinds of wastes, the TRITO is at low energy consumption and at low noise; so particularly fitted to small and medium companies.

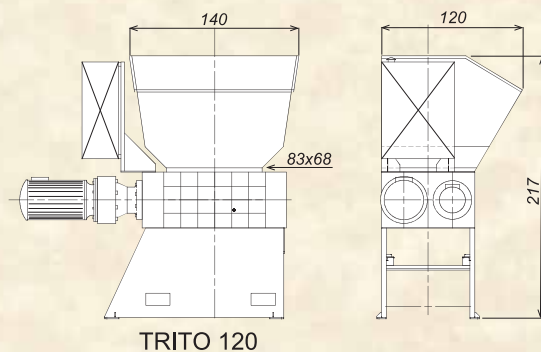
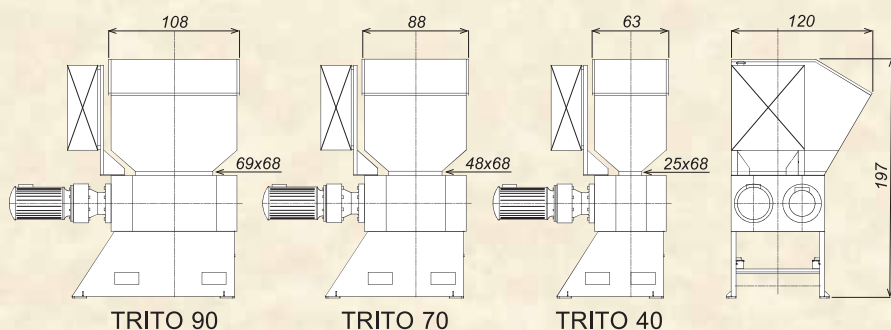

Prodotto riciclabile

I prodotti sono soggetti ad evoluzione tecnica ed i prospetti potrebbero non essere aggiornati.

As it is company policy to aim continual improvement, the Manufacturer reserves the right to modify any part of the design or specifications without prior notice and without the obligation to make such modifications retrospectively.

VERSIONI	MOTORIDUTTORI 3 FASI	Kw	POTENZA IN CV	PESO KG.	DIMENSIONI CM.	LARGHEZZA	LUNGHEZZA	ALTEZZA
TRITO 40	n° 1	7,5	10	720		120	143	197
	n° 2	4/7,5	5,5/10	820		120	143	197
TRITO 70	n° 2	4/9,5	5,5/12	980		120	169	197
TRITO 90	n° 2	4/11	5,5/15	1160		120	188	197
TRITO 120	n° 2	4/15	5,5/20	1410		120	220	217
VERSION	3-PHASE MOTORS	Kw	POWER IN HP	WEIGHT KG.	DIMENSIONS CM.	WIDTH	LENGHT	HEIGHT

