

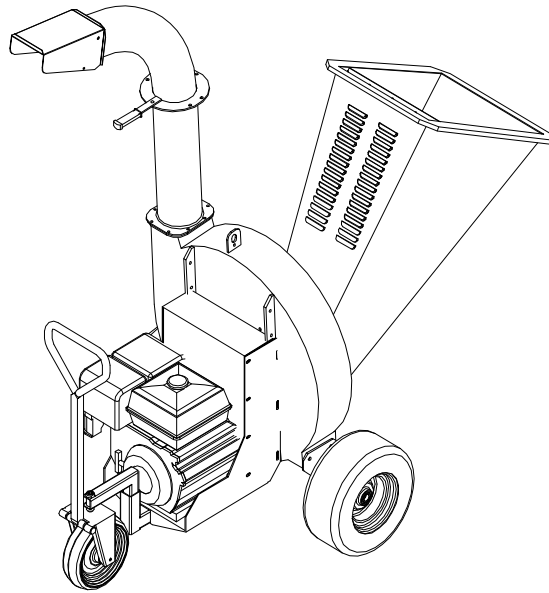

## BIO 190



- Elettrico - Electric 10 HP / 7.5 KW 380 V
- Benzina - Petrol 13 HP / 9,6 KW Honda GX 390
- Trattore - Tractor 20÷30 HP
- Rotore a 24 martelli reversibili - Rotor with 24 reversible hammers
- Crivello di raffinazione intercambiabile - Refining and interchangeable screen
- 2 ruote per spostamento - 2 wheels
- 3ª ruota con timone - third wheel with drawbar
- Cippatore frontale a 3 lame - Front side chipper with 3 blades
- Ventola di scarico a mt 2,00 girevole 360° - Blower up to 2,00 mts
- Produzione - Production 7÷8 m<sup>3</sup> / h

	Lame N°	C/lame N°	Martelli N°	Ø Triturabile	Ø Cippabile	Peso Kg	Dimensioni cm			Imballo cm		
	2+1	2	24	-	10	300	Lar	Lun	Alt	Lar	Lun	Alt
							Bre	Len	Hig	Bre	Len	Hig
No. Blades	No. C/blades	No. Hammers	Ø Triturable	Ø To be cut	Kg Weight	cm Dimensions			cm Packing			



Scheda n. B190-01 | Biotrituratore Bio 190

Caravaggi Srl

Via Monte Adamello, 20 - 25037 Pontoglio - BS (ITALY)

Tel. +39 030 7470464 - Fax +39 030 7470004 - Email info@aravaggi.com